

Groupe de condensation / Condensing unit
Code tension / Voltage code : T

TFH2480ZBR

Froid commercial négatif (BP)
Low back pressure commercial application

400-440V / 50-60Hz - 3~

R404A

N°426GU-T-VR ind c

Conditions <i>Conditions</i>	fréquence <i>frequency</i>	Prod frigorifique nominale° / <i>nominal refrigerating capacity °</i>			Puis. sonore <i>Sound level</i>
		Watts	Kcal/h	BTU/h	
Standard	50 Hz	2217	1907	7564	76 dBA
Standard	60 Hz	2601	2237	8875	

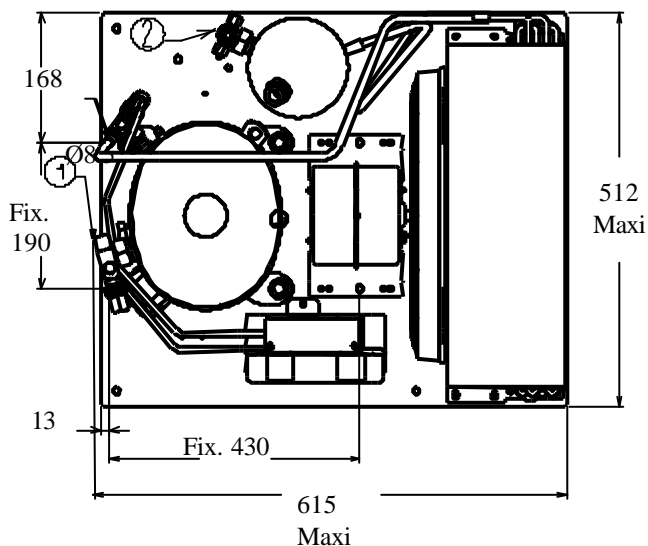
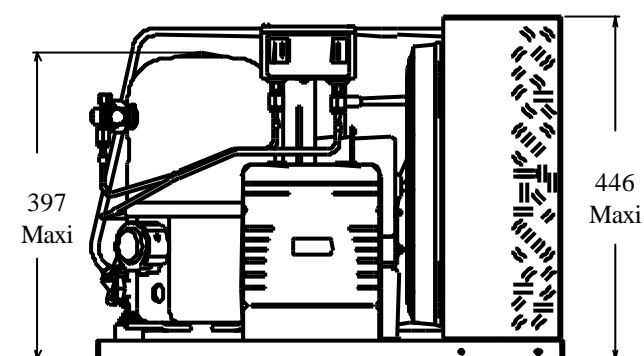

Poids net / Net weight :	53 Kg
Détente / Expansion device :	Détendeur Expansion valve
Débit d'air / Air flow :	2200 / 2500 m ³ /h
Intensité / Current	
nom. / <i>Rated current RLA :</i>	3.2 / 3.56 A
max. / <i>Max current :</i>	5.2 / 5.36 A
dém. / <i>Start current LRA :</i>	24 / 26.2 A
Ap. Electrique / Electrical equipment :	TRI
Fiche technique compresseur / Compressor technical data sheet :	126GU-T
Ventilateur / Fan motor :	
Vitesse / <i>R.P.M :</i>	1440 / 1650 tr/min
Puis. mécanique / <i>Shaft power :</i>	90 W
Diam. hélice / <i>Fan blade dia. :</i>	Ø 356 mm
Protection / <i>Protection :</i>	Protecteur/Overload IP44
Condenseur / Condenser :	356/6500
Réservoir de liquide / Receiver :	
Volume / <i>Capacity :</i>	2.35 L
PMS / <i>Max. service pressure :</i>	32 Bars
Grille / Fan guard :	maille < à 8mm Grid space < 8mm

Pour conduites Æ ext / For tubing O.D.

Aspirat° 1 / <i>Suction 1</i>	Vanne Orientable / Rotalock Valve	15.9 (5/8")	à Braser/Brazed
Départ liquide 2 / <i>Liquid line 2</i>	Vanne Orientable / Rotalock Valve	9.5 (3/8")	à Braser/Brazed

Les caractéristiques données dans cette fiche technique peuvent évoluer sans avis préalable, avec les améliorations que 'TECUMSEH EUROPE' entend toujours apporter à sa production.
'TECUMSEH EUROPE', in a constant endeavour to improve its products reserves the right to change any information contained in this leaflet without prior warning.



TFH2480ZBR	Tension T : 400V 3~ 50Hz / 440V 3~ 60 Hz	R404A	N°426GU-T	Ind c
-------------------	---	--------------	------------------	--------------

Les performances sont données dans les **conditions Standard TE** : Gaz aspirés : 32°C
Sous refroidissement: 2°K

The performance data are in **Standard TE conditions** : Return gas : 32°C
Subcooling : 2°K

50 Hz R404A

5 T ambience	6 T évaporation	(°C)	-40	-35	-30	-25	-20	-15	-10
25	1 P frigorifique	(W)	969	1412	1859	2311	2767	3228	3694
	2 P absorbée	(W)	809	1034	1257	1480	1703	1925	2147
	3 I absorbée	(A)	1.71	2.03	2.35	2.67	3	3.34	3.67
	4 Tc	(°C)	31.7	34.4	37	39.4	41.8	43.9	46
32	1 P frigorifique	(W)	824	1226	1641	2069	2509	2963	3429
	2 P absorbée	(W)	829	1064	1306	1553	1807	2067	2333
	3 I absorbée	(A)	1.71	2.03	2.35	2.68	3.01	3.36	3.71
	4 Tc	(°C)	37.9	40.6	43.1	45.5	47.7	49.9	51.8
43	1 P frigorifique	(W)			1356	1740	2150	2585	3046
	2 P absorbée	(W)			1382	1668	1970	2289	2625
	3 I absorbée	(A)			2.35	2.68	3.03	3.39	3.76
	4 Tc	(°C)			52.7	55	57.1	59.2	61

60 Hz R404A

5 T ambience	6 T évaporation	(°C)	-40	-35	-30	-25	-20	-15	-10
25	1 P frigorifique	(W)	1140	1662	2186	2713	3241	3772	4305
	2 P absorbée	(W)	972	1248	1531	1820	2116	2419	2728
	3 I absorbée	(A)	1.6	1.99	2.39	2.81	3.26	3.73	4.22
	4 Tc	(°C)	32.3	34.8	37.4	39.9	42.3	44.7	47.1
32	1 P frigorifique	(W)	969	1443	1930	2429	2939	3462	3996
	2 P absorbée	(W)	996	1285	1590	1910	2245	2597	2963
	3 I absorbée	(A)	1.61	1.98	2.39	2.82	3.27	3.75	4.26
	4 Tc	(°C)	38.5	41	43.5	45.9	48.3	50.6	52.9
43	1 P frigorifique	(W)			1596	2043	2518	3020	3550
	2 P absorbée	(W)			1683	2051	2449	2877	3334
	3 I absorbée	(A)			2.39	2.83	3.29	3.79	4.31
	4 Tc	(°C)			53.1	55.4	57.7	59.9	62.1

1 = refrigerating capacity 2 = watt input 3 = current 4 = condensating temperature 5 = ambient temperature 6 = evaporating temperature

Nota : Les caractéristiques données dans cette fiche technique peuvent évoluer sans avis préalable, avec les améliorations que "TECUMSEH EUROPE" entend toujours apporter à sa production.

Note : "TECUMSEH EUROPE", in a constant endeavour to improve its products reserves the right to change any information contained in this leaflet without prior warning.